

Part number

CAO 16 X



Brief description:

hoods with two levers, size "77.27", side entry, Pg21, metal version, IP66 (EN 60529) and IP69K (DIN 40050 - 9) degree of protection.

Product description

Version	metal version
Series	Hoods for 2 levers, without gasket
Product type	with 2 levers, without gasket
Variant	side entry
Style	high construction
Family	CLASS enclosures
Size	size "77.27"

Technical data

Material	metal
IP degree of protection	IP66 (and IP69K DIN 40050 - 9)
Cable entry	Pg21

Further technical details

Weight	296,00 g
---------------	----------

Approvals / Standards

Quality mark	 (type:4/4X/12),  , EAC
Conformity	CQC, CE

General ordering information

EAN13 code	8015747006262
Tariff number	85369095

Packaging Information

Packaging length	250,00 mm
Packaging height	145,00 mm
Packaging width	300,00 mm
Packaging weight	2,96 kg
Packaging volume	10,88 dm ³
Packaging description	Carton box
Packaging quantity	10 Pcs
Packaging EAN code	8015747215572
Sub-packaging weight	1,48 kg
Sub-packaging description	Carton Box
Sub-packaging quantity	5 Pcs
Sub-packaging EAN barcode	8015747006279

Part number

CAO 16 X



Catalogue drawings

CHO X (CAO X) - MHO X (MAO X)

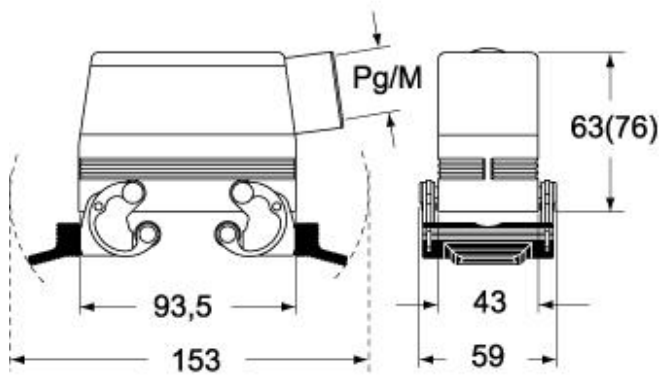

CHV X (CAV X) - MHV X (MAV X)

